

# INSTALLATION INSTRUCTIONS

## FOR MODEL 2 LEVEL WINDER KIT #256110

This Level Winder is designed specifically for the Ramsey Winch Models Y200/Y300 Series Winches (Y200/Y300, HY200/HY300 or DCY200/DCY300), which is 6.31 inches between drum flanges and the RPH8 Winch with Y drum which is 6.50 inches between drum flanges.

**NOTE: IF LEVEL WINDER IS BEING INSTALLED ON A CAR CARRIER (ROLLBACK), IT IS NECESSARY TO ALSO INSTALL RAMSEY ROLLER GUIDE KIT, PART NO. 256053. FAILURE TO DO SO MAY CAUSE DAMAGE OR BREAKAGE TO THE WINCH LEVEL WINDER OR VEHICLE.**

### INSTALLATION PROCEDURE

Disengage the winch clutch and free spool all the cable off the winch and lay it in a line on the ground behind the truck. Disconnect the end of the cable from the cable drum anchor. Drill two .562 diameter holes through the horizontal flange of the forward most winch mounting angle as shown in FIG. 1.

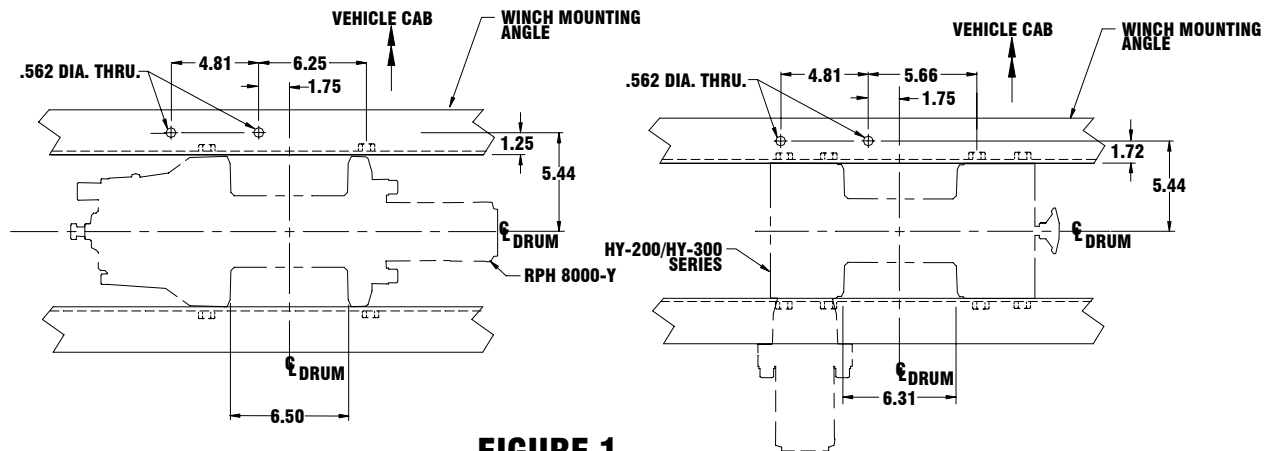
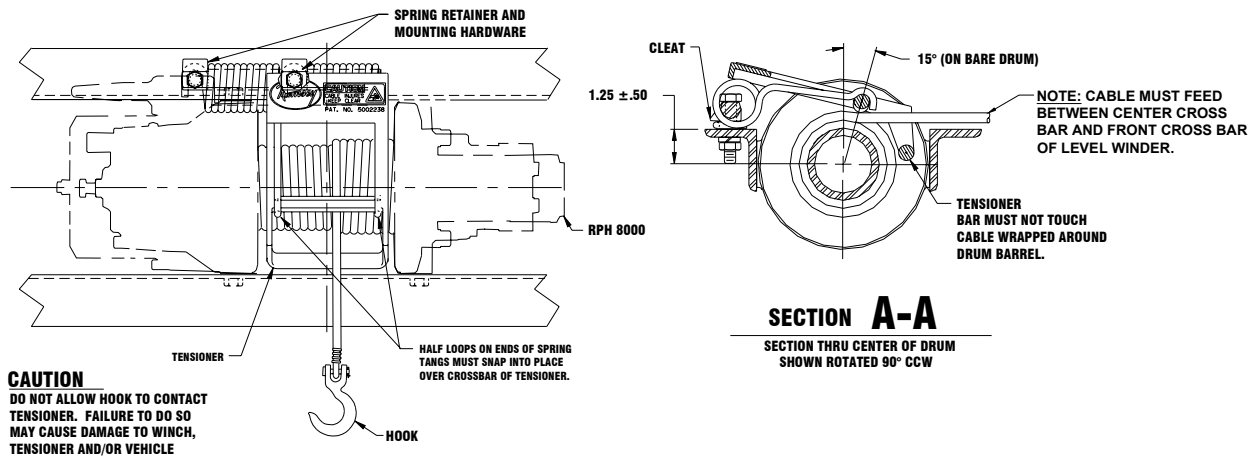

**FIGURE 1**

Insert the spring retainer into the springs so that the cleats of the retainer will extend toward the vehicle cab when the assembly is in place. Slide the retainer so that the holes in the retainer line up with the hold down loops in the springs. Position the holes in the retainer over the .562 diameter holes previously drilled in the flange of the winch mounting angle. Loosely attach the spring retainer and springs to the flange of the winch mounting angle using the 1/2 inch diameter capscrews, nuts and lockwashers. After making sure the springs and spring retainer are aligned squarely with the winch, as shown in FIG. 2., tighten the capscrews securely so that the springs are clamped hard down onto their mounting surface.

**NOTE: The surface to which the springs are bolted must be  $1.25 \pm .50$  inch above the centerline of the drum barrel.** See FIG. 2, SECTION A-A.

Insert the end of the cable into the opening of the tensioner so that it passes under the center cross bar and over the front cross bar and install the cable into the cable anchor. Bring the tensioner up to the winch and lift up first one then the other of the spring tangs while sliding the center cross bar of the tensioner under the tangs. A pry bar will be necessary to lift up the tangs. Push the tensioner toward the spring until the half loops at the end of each spring tang snap into place over the center cross bar of the tensioner. See FIG. 2.



**FIGURE 2**

Engage the clutch and run the winch in the reel in direction winding about five wraps of cable onto the drum and stop. Using a hammer tap these five wraps tightly over against the cable anchor flange of the cable drum. Finish winding all the cable onto the cable drum. As cable winds onto the drum, watch the tensioner. Tensioner must be free to move without obstruction to function properly. If tensioner touches any surrounding structure, correct the problem.

**CAUTION: STOP REEL IN OF CABLE BEFORE THIMBLE/HOOK ENTERS LEVEL WINDER. FAILURE TO DO SO MAY CAUSE DAMAGE OR BREAKAGE TO THE WINCH, LEVEL WINDER, OR VEHICLE.**

### OPERATION

Lay cable out in a straight line behind the truck to prevent kinking before beginning to wind in. It is not necessary to walk in with the cable, let your Level Winder do the work.

PART NO.	QTY.	DESCRIPTION
414558	2	CAPSCREW 1/2-13NC X 3 LG. HX.HD. ALL THRD. GR. 5, PLTD.
418069	2	NUT-HEX. 1/2-13NC REG. PLTD.
418218	2	LOCKWASHER 1/2 MED. SECT. PLTD.
434254	1	DECAL
494115	2	SPRING, LH
688489	1	TENSIONER-CABLE
688524	1	RETAINER-SPRING, LH



**RAMSEY WINCH COMPANY**  
**P.O. BOX 581510**  
**TULSA, OKLAHOMA 74158**

KI-912598-1202-B