



**Ramsey Winch Company  
OWNER'S MANUAL  
BADGER Electric Winch  
Model BADGER 2500  
W/Wireless Remote Control**



Note: Fairlead does not attach directly to winch. Winch shown with mounting plate, sold separately.

<b>BADGER 2500 WINCH</b>						
LAYER OF CABLE		1	2	3	4	5
Rated line pull per layer (lbs)		2500	2090	1800	1580	1400
	(kgs)	1133	947	815	716	634
Cumulative cable capacity per layer (3/16" - 4.8mm - dia. cable)	(ft)*	7	15	25	37	50
	(m)*	2.12	4.56	7.6	11.3	15.2
*CABLE MUST BE UNIFORMLY WOUND ONTO DRUM.						
Line pull first layer	(lbs)	NO LOAD	500	1000	1500	2000
	(kgs)		227	453	680	906
Line speed first layer	(fpm)	18	17	15	12	11
	(mpm)	5.5	5.1	4.6	3.7	3.4
Amp draw	(12v)	36	60	90	116	140
						160

**Congratulations**

You have purchased the finest winch available in its service class. It features a highly efficient 3 stage planetary gear set which transmits torque from a permanent magnet motor. A safe positive clutch allows free spooling for quick cable deployment. Your Ramsey winch was designed and manufactured to provide you with the utmost in utility. As with any device that combines power and movement in its use, there are dangers if improperly used. At the same time, there are easier and faster ways for getting the job done if certain precautions are taken first. Please read this manual carefully. It contains useful ideas in obtaining the most efficient operation from your Ramsey Winch and safety procedures you need

to know before beginning use. When you follow our guidelines for operation, your Ramsey winch will give you many years of satisfying service. Thank you for choosing Ramsey. You will be glad you have one working for you.

**Please Note:** Ramsey Badger 2500 winches are designed primarily for general use. This winch is not designed to be used in industrial applications (car haulers/carriers, wreckers, hoisting, etc.), and Ramsey does not warrant it to be suitable for such use. Ramsey makes a separate, complete line of winches for industrial/commercial use. Please contact the factory for further information.

 **CAUTION:** Read and understand this manual before installation and operation of winch. See Safety Precautions.

Contents	
Performance Specifications	1
Safety Precautions .....	2
Tips for Safe Operation .....	2
General Installation .....	3
Installation .....	3
Electrical Schematic .....	4
Techniques of Operation .....	5
General Operating Instructions	5
Wireless Remote Control Operation	5
Maintenance .....	6
Troubleshooting Guide .....	7
Winch Parts List .....	8-9
Warranty .....	Back Cover

- I. Keep the duration of your pulls as short as possible. If the motor becomes uncomfortably hot to the touch, stop and let it cool for a few minutes. Do not pull more than one minute at or near the rated load. Do not maintain power to the winch if the motor stalls. Electric winches are for intermittent usage and should not be used in constant duty applications.
- J. Do not use winch in hoisting applications due to required hoist safety factors and features.
- K. Do not exceed maximum line pull ratings shown in tables. Shock loads must not exceed these ratings.
- L. To respool correctly, it is necessary to keep a slight load on the cable. Do not allow the cable to slip through your hand and do not approach the winch too closely. When all the cable except a few feet is in, stop and finish spooling in cable by rotating the drum by hand with clutch disengaged. Always use hook strap to hold hook when spooling.
- M. Do not use the winch to hold a load on the trailer while towing. Secure the load to the trailer with straps or tie-downs. The winch is not designed to be a load holding device.



### Safety Precautions To Guard Against Possible Injury

- A. Keep yourself and others a safe distance to the side of the cable when pulling under load.
- B. Do not step over a cable, or near a cable under load.
- C. Use supplied hook strap when handling hook for spooling wire rope.
- D. Do not use a vehicle to pull a load on the winch cable. This could result in cable breakage and/or winch damage.
- E. Use a heavy rag or gloves to protect hands from burrs when handling winch cable.
- F. Apply blocks to wheels when vehicle is on an incline.
- G. Winch clutch should be disengaged when winch is not in use and fully engaged when in use.
- H. Modification, alteration, or deviation to the winch should only be made by Ramsey Winch Company.



### Tips for Safe Operation

Don't underestimate the potential danger in winching operations. Neither should you fear them. Do learn the basic dangers and avoid them.

Observe spooling of cable onto drum. Side pulls can cause cable to pileup at one end of the drum. To correct uneven stacking, spool out that section of the cable and move it to the other end of the drum and continue winching. Uneven spooling which causes cable pileup can interfere with the winch tie rods causing damage to the winch.

Store the wireless remote control transmitter in a safe place where it will not become damaged. Inspect it before you use it. When ready to begin winching, push and hold the On/Off button on the transmitter until it flashes. Do not engage clutch with motor running. Never connect the hook back to the cable. This causes cable damage. Always use a sling or chain of suitable strength. Observe your winch while winching. If possible, while standing at a safe distance. If you use vehicle drive to assist, stop and get out every few feet to assure the cable is not piling up in one corner. Jamming cable can break your winch.

When double lining during stationary winching, do not attach tow hooks to winch mounting plate. Since the greatest pulling power is achieved on the innermost layer of your winch, it is desirable to pull off as much line as you can for heavy pulls. If this is not practical, use a snatch block and double line arrangement.

Neat, tight spooling avoids cable binding which is caused when a load is applied and the cable is pinched between two other wraps of cable. If this happens, alternately power the winch in and out a

few inches. Do not attempt to work a bound cable under load, free by hand.

## General Installation

The winch shown in this owners manual is designed solely and exclusively for non-industrial applications. All other applications will void warranty.

It is very important that the winch be mounted on a flat surface, with the cable underwound as shown in the dimensional drawing below.

Tighten mounting bolts to 16 ft-lbs (22 Nm) torque. CAUTION: Supplied 7/8" long mounting bolts with lockwashers are for a recommended winch mounting plate thickness of 3/16". If a different mounting plate thickness is used, the bolt length must be adjusted accordingly or damage to winch may occur. Replacement bolts must be SAE Grade 5 or equivalent.

Refer to *Installation and Operating Instructions for Ramsey Wireless Remote Control* for electrical connections and installation.

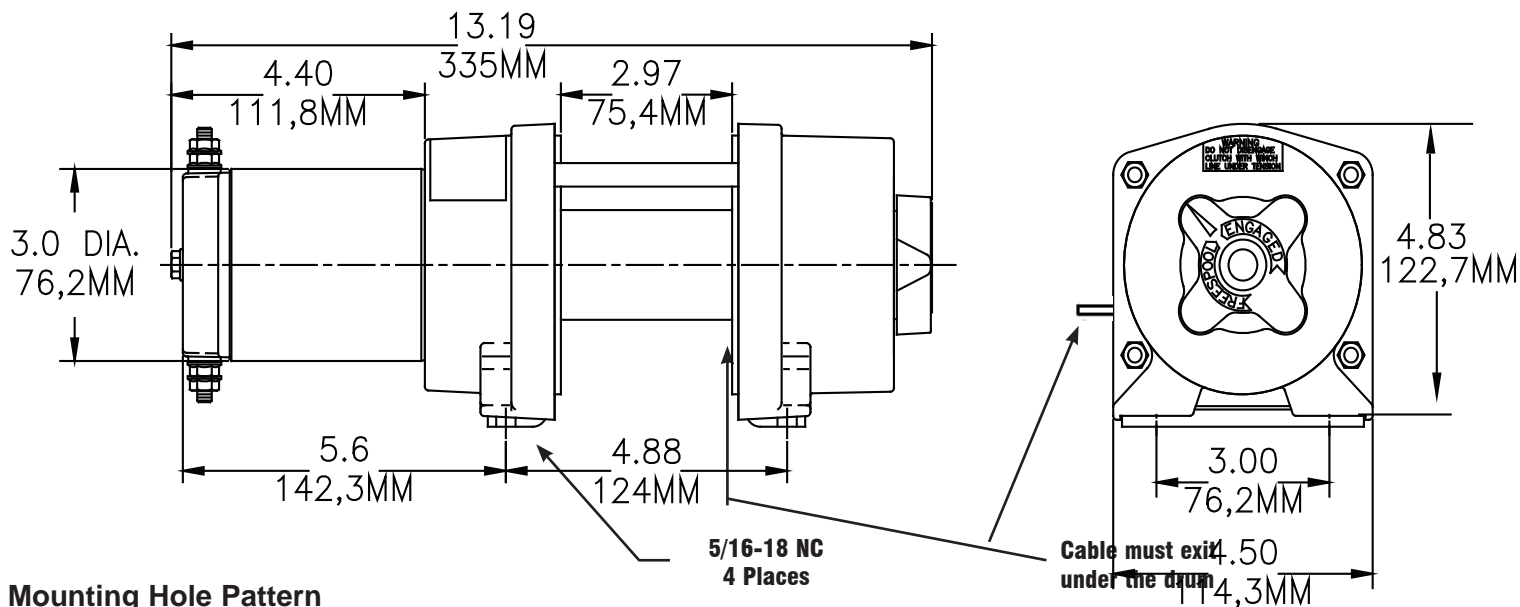

### Mounting Hole Pattern

Four 11/32" (8,6 mm) diameter holes on 4.88" (124 mm) x 3.00" (76,2 mm) pattern

# Electrical Schematic

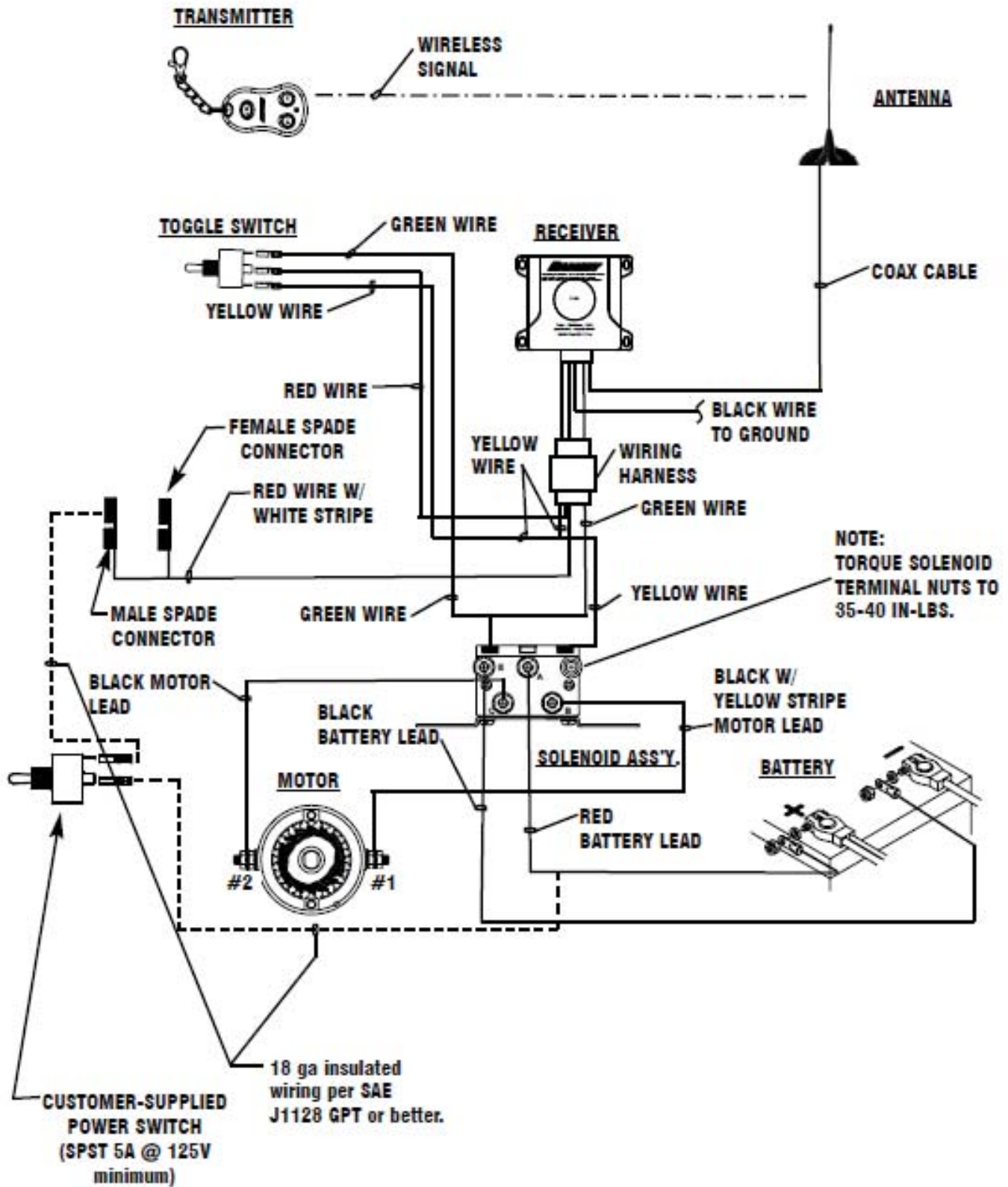

## Techniques of Operation

The best way to get acquainted with how your winch operates is to make a few test runs before you actually need to use it.

Plan your test in advance. Remember you hear your winch as well as see it operate. Get to recognize the sound of a light steady pull, a heavy pull, and sounds caused by load jerking or shifting. Soon you will gain confidence in operating your winch and its use will become second nature with you.

When pulling a heavy load, place a blanket, jacket or tarpaulin over the cable five or six feet from the hook. It will slow the snap back in the event of a broken cable.

Plan your pull. You can't always hook up and pull out in one step. Examine all the areas for anchoring possibilities as well as leverage situations, direction, and goal.

## General Operating Instructions

The winch clutch allows rapid unspooling of the wire rope for hooking onto the load or anchor point. The clutch is operated by the shifter located on the end of the winch as follows:

1. To disengage the clutch, turn the clutch shifter to the "FREESPOOL" position. Wire rope may now be freespooled off the drum.
2. To engage the clutch, turn the clutch shifter to the "ENGAGED" position. The winch is now ready for pulling.



Your battery must be kept in good condition. A fully charged battery and proper connections are essential. Run the vehicle engine during winching operations to keep battery charged.

## Wireless Remote Control Operation

Caution: When the transmitter reaches a temperature below 0°F (-18°C) it will not operate. In extremely cold temperatures, keep transmitter in a pocket of innermost layer of clothing when not in use.

The transmitter has push buttons labeled according to their function. Make sure the motor has stopped fully before reversing to prevent premature solenoid failure. To operate the winch hold "ON/OFF" button for 2 seconds to activate the "IN" and "OUT" functions. Run winch forward and reverse to check connection and to verify winch operating directions. The transmitter is clearly labeled and a red LED flashes when the winch is in operation. Pushing both buttons at the same time will not damage your winch in any way. Press and hold the "ON/OFF" button on the transmitter to disable the transmitter when winch is not in use. This will prolong the battery life of the transmitter. The transmitter automatically turns off after 20 minutes.

**Refer to page 5 of Wireless Remote Control Installation Instructions for remote operation notes.**

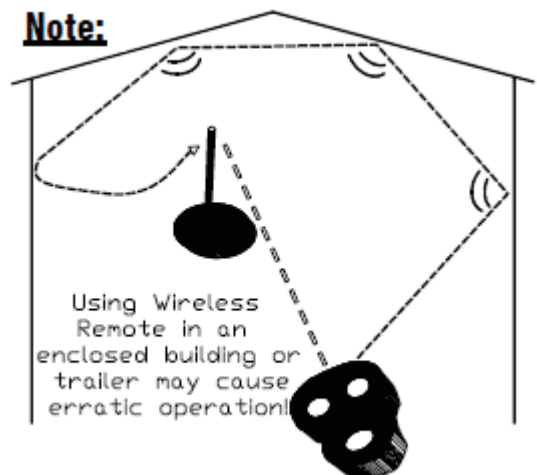

## Maintenance

Corrosion on electrical connections will reduce performance or may cause a short. Clean all connections. In salty environments use a silicone sealer to protect from corrosion.

See supplied instructions for programming a replacement transmitter.

All moving parts in the winch are permanently lubricated with broad temperature range lithium-based grease.

Lubricate cable periodically using light penetrating oil. Inspect for broken strands and replace if necessary. If the cable becomes worn or damaged, it must be replaced.

To minimize corrosion of the internal motor components that may occur due to condensation, power the winch in or out periodically. Energizing the motor will generate heat, which will dissipate any moisture buildup in the motor. This should be performed at periodic intervals (such as with each oil change of your vehicle). Note: Refer to the Troubleshooting Guide if the motor has been submerged.

## Cable Installation

Note: Cable should be installed so that it feeds from the bottom of the drum.

Unwind the new cable by rolling it out along the ground to prevent kinking. Remove old cable and observe the manner in which it is attached to the cable drum flange, watching carefully for the cable anchor puck.

Before installing the new cable assembly, securely wrap the end of the cable with tape to prevent fraying.

Slide the cable through narrow end of the pocket against drum flange and wrap the cable around the anchor puck. Pull the cable and anchor back into the wide end of the pocket leaving approximately 1/8" beyond edge of pocket as shown. Use a hammer and drift punch to drive the back side of the wire rope, firmly seating the wire rope and anchor into the pocket.

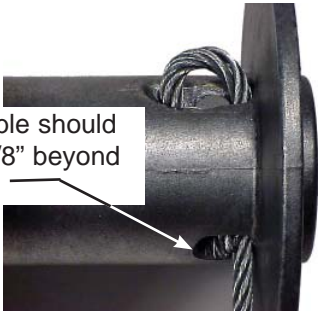

The short end of the cable should extend approximately 1/8" beyond the top edge of pocket.

Wind on the cable by pulling in a light load to keep the tension constant. Allow the cable to swivel by using a length of chain or a swivel block between the cable hook and the load.

# Trouble Shooting Guide

CONDITION	POSSIBLE CAUSE	CORRECTION
MOTOR RUNS IN ONLY ONE DIRECTION	Defective solenoid or stuck solenoid.	Jar solenoid assy to free contacts. Check each solenoid by applying +12 volts to coil terminal (it should make an audible click when energized).
	Defective remote control or low battery in transmitter.	Check winch operation with auxiliary toggle switch. Check battery in transmitter.
MOTOR RUNS EXTREMELY HOT	Long period of operation.	Cooling-off periods are essential to prevent overheating.
MOTOR RUNS, BUT WITH INSUFFICIENT POWER OR WITH LOW LINE SPEED	Insufficient battery	Test for faulty vehicle battery.
	Bad connection	Check battery cable for corrosion; clean and grease
	Insufficient charging system.	Replace with larger capacity charging system.
MOTOR RUNS, BUT DRUM DOES NOT TURN	Clutch not engaged.	If clutch engaged but symptoms still exist, it will be necessary to disassemble winch to determine cause and repair.
MOTOR WILL NOT OPERATE	Stuck or defective solenoid.	Jar solenoid assy to free contacts. Check solenoid by applying +12 volts to coil terminal (it should make an audible click when energized).
	Defective remote control or low battery in transmitter.	Check winch operation with auxiliary toggle switch. Check transmitter battery
	Defective motor.	If solenoids operate, check for voltage at armature post; replace motor.
MOTOR WATER DAMAGED	Loose connections.	Check all electrical connections from the battery to the motor.
	Submerged in water or water from high pressure car wash.	Allow to drain and dry thoroughly, then run motor without a load in short bursts to dry windings.
WINCH RUNS IN OPPOSITE DIRECTION OF TRANSMITTER BUTTONS	Motor leads crossed.	Reverse electrical connections to motor.
	Solenoid control wires crossed.	Reverse position of green and yellow wires on solenoid assy.

## Parts List

ITEM NO	QTY	PART NO.	DESCRIPTION
1	1	251214	MOTOR KIT
2	1	251247	MOTOR END GEAR SET KIT
3	1	251191	CLUTCH KIT
4	1	251192	CABLE DRUM KIT
5	1	251193	CABLE & HOOK KIT
6	1	251213	CLUTCH END GEAR KIT
7	1	251236	ROLLER FAIRLEAD KIT
8	1	251195	BUSHING KIT
9	1	251196	TIE BAR KIT
10	1	299721	ELECTRICAL WIRING KIT (WIRELESS)
11	1	282058	WIRELESS RECEIVER & TRANSMITTER KIT
12	1	251190	WIRELESS TRANSMITTER KIT
13	1	251234	SOLENOID KIT
14	1	251235	TOGGLE SWITCH KIT
15	1	251251	ANTENNA KIT
16	1	256116	BRAKE KIT



**BADGER 2500 PARTS**

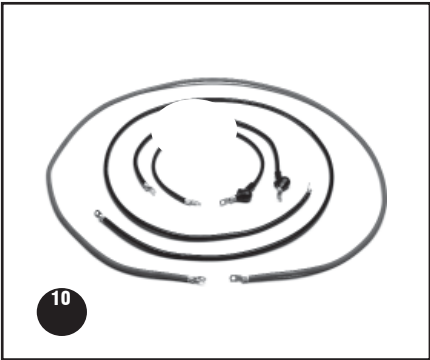
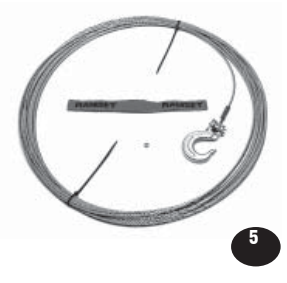
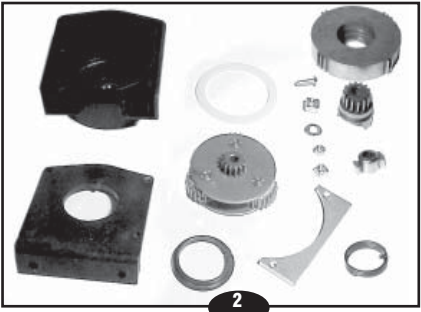
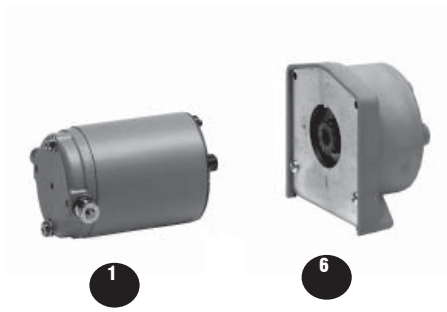

## Warranty Information

Ramsey Winches are designed and built to exacting specifications. Care and skill go into every winch we make. If the need should arise, warranty procedure is outlined on the back of your self-addressed, postage paid warranty card. Please read and fill out the enclosed warranty card and send it to Ramsey Winch Company. If you have any problems with your winch, please follow instructions for prompt service on all warranty claims.

### Limited Lifetime Warranty

Ramsey Winch offers a limited lifetime warranty for each new Ramsey winch against manufacturing defects in workmanship and materials on all manufactured components.

Warranty registration cards for each winch must be submitted at the time of purchase, or within 90 days. Online registration of your winch is available at [www.ramsey.com](http://www.ramsey.com).

New cable assemblies are warranted against defects in workmanship and materials. No warranty applies after initial use.

All Ramsey mounting kits and other accessories carry a 1- year limited warranty against defects in materials and workmanship.

This warranty is void if winch is used in industrial applications.

Electrical components consisting of motors, solenoids, wiring, wire connectors, and associated parts carry a limited 1-year warranty.

The obligation under this warranty, statutory or otherwise, is limited to the replacement or repair at the manufacturer's factory, or at a point designated by the manufacturer, of such part as shall appear to the manufacturer, upon inspection of such part, to have been defective in material or workmanship. This Warranty does not obligate Ramsey Winch Company to bear the cost of transportation charges in connection with the replacement or repair of defective parts, nor shall it apply to a product upon which repairs or alterations have been made, unless authorized by the manufacturer, or for equipment misused, neglected, or improperly installed.

**Important notice:** To the fullest extent permitted by applicable law, the following are hereby excluded and disclaimed: 1. All warranties of fitness for a particular purpose; 2. All warranties of merchantability; 3. All claims for consequential or incidental damages. There are no warranties that extend beyond the description that appears on the face hereof.

Some states do not allow the above exclusions or disclaimers in consumer transactions and as such this disclaimer/exclusion may not apply to your particular case.

To the extent such warranties of fitness for a particular purpose or merchantability are deemed to apply to this product, they exist only for so long as the express limited warranty elsewhere set forth is in existence.

Ramsey Winch Company makes no warranty in respect to accessories, same being subject to the warranties of their respective manufacturers.

Ramsey Winch Company, whose policy is one of continuous product improvement, reserves the right to improve any product through changes in design or materials as it may deem desirable without being obligated to incorporate such changes in products of previous manufacture.

If field service at the request of the buyer is rendered and the fault is found not to be with Ramsey Winch Company's product, the buyer shall pay the time and expense of the field representative. Bills for service, labor or other expenses which have been incurred by the buyer without express approval or authorization by Ramsey Winch Company will not be accepted.

This Warranty gives you specific legal rights and you may also have other legal rights which vary from state to state.



### Quality Management System



RAMSEY WINCH COMPANY  
P.O. BOX 581510 TULSA, OKLAHOMA 74158-1510 USA  
PHONE: (918) 438-2760 FAX: (918) 438-6688  
<http://www.ramsey.com>